

AD-S

Hydraulic Press Brakes

Series



Perfect Precision

Deep And Fast Bending

Efficient

Winning

Elegant Design



As a total supplier for sheet metal manufacturing with almost 70 years of experience, Durma understands and recognizes the challenges, requirements and expectations of the industry. We strive to satisfy the ever higher demands of our customers by continuously improving our products and processes while researching and implementing the latest technologies

In our three production plants with a total of 150.000 m², we dedicate 1,000 employees to delivering high quality manufacturing solutions at the best performance-to-price ratio in the market.



PRODUCTION IS
MORE EFFECTIVE NOW

From the innovations developed at our Research & Development Center to the technical support given by our worldwide distributors, we all have one common mission: to be your preferred partner.

Durmazlar offers it's machines to the world markets under the Durma brand.



1

High technology,
modern production
lines



2

Top quality
components



3

High quality
machines designed
in R&D Centre

AD-S

Feel The Force and Performance

Our Machines are shaped with our superior experience and state of art technology, special designed as well as excellent combined component its the fastest , most reliable and prices press brakes on its category. With its rigid body structure, robust back gauge and high standard components it ensures long lasting and precision applications.

Therefore with *DURMA* press brakes you can always achieve perfect result.

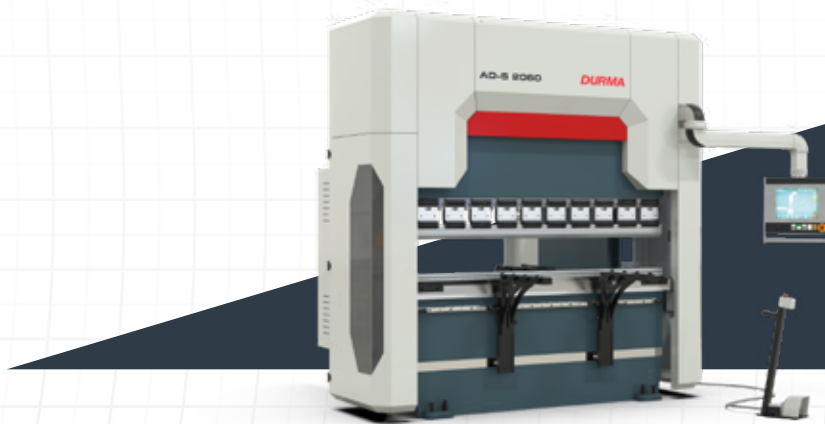

Fast, Precise and Perfect Bending

- Precise bending result at fast speed
- Minimalized tool change and adjustment time
- Maximized speed and safety



Production is *More Effective Now.*

AD-S Series Hydraulic Press Brake



Perfect and Fast Bending

Perfect components for precision

With Easy to use control unit, stable body structure, perfect design, low operating cost, different tool usage options, maximum safety standards, DURMA press brake is the best in the world in its segment.



Why DURMA Press Brakes

- Better and faster bending
- Stronger and rigid body structure
- High sensitivity and repeatability
- High technology excellent equipment
- Low service cost
- Reliability



AD-S

FAST, EFFICIENT, MODERN

AD-S Series hydraulic press brakes, designed with high technology to increase efficiency on precise part bending. Quality approved components. Stress relieved for long life and precise bending.



General Specifications

- High sensitivity, Stress relieved steel construction body, long life Mono Block Frame
- Automatic calibration and first start up
- DURMA designed and copyrighted guiding system
- Ball Screw and linear guide integrated perfect back gauge system
- Durable, long life and sensitive bending capable special hardened top tools
- Suitable for segmented tools special and fast tool holding system
- Sensitive solutions on long and deep bending
- High accuracy linear scales
- CE safety standards
- Best quality world wide accepted hydraulic and electric components

STRONG BACK GAUGE SYSTEM

- Precise
- Reliable
- Strong

- Fast and high accuracy
- Safe movement
- Resistance to crash
- Maintenance free
- Adjustment availability at every point

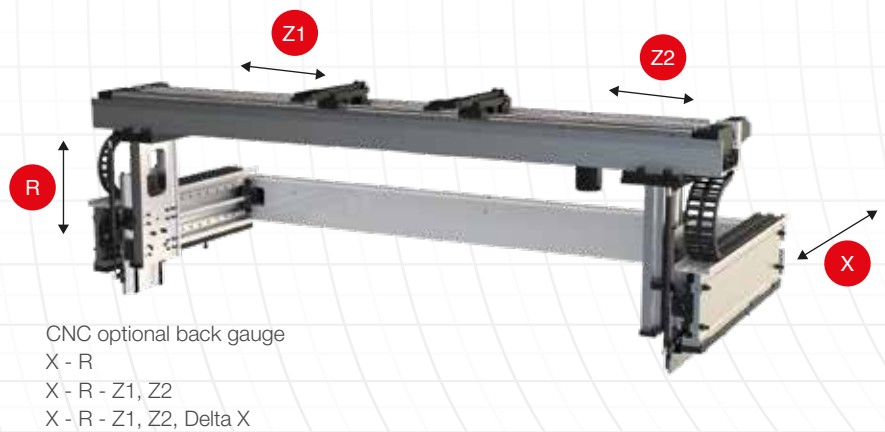
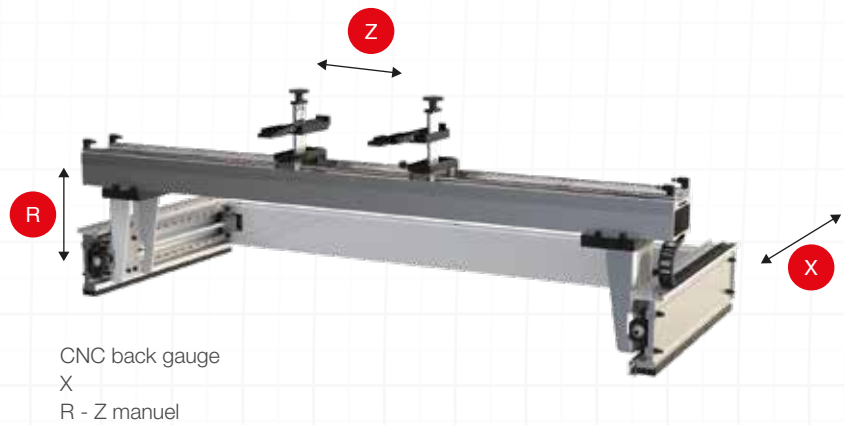

Why DURMA Back Gauge ?

The most important feature to achieve perfect bending is the stability and the design of the back gauge, which allows an impeccable and correct product to be produced.

The high speed **double ballscrew** back gauge system movement is also supported with **double linear guides**, which helps the back gauge achieve long life, greater sensitivity and strengthens against any collisions.

Special designed finger blocks with steps to achieve maximum stability can also be supplied for every kind of bending solution.

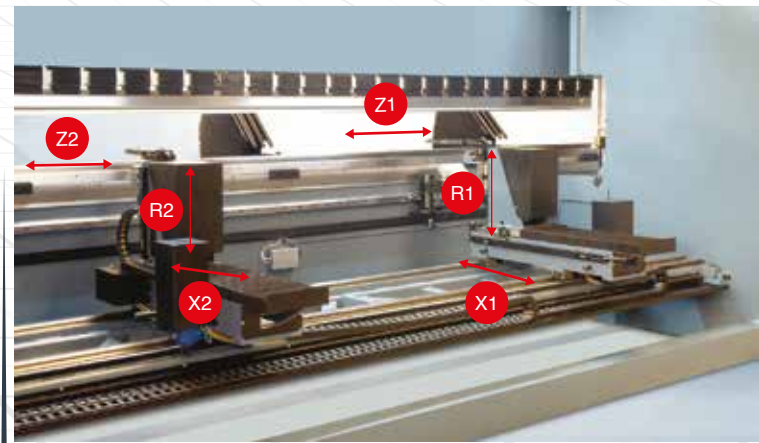

CNC optional back gauge
X1 - X2, R1 - R2, Z1 - Z2

TOOL HOLDERS AND TOOLS

Bending performance increased using with high quality European clamping system and easy to use. Narrow table designed for European style tool holder and Z bending.

DURMA is your solution partner with various tool options.



European
Clamping System

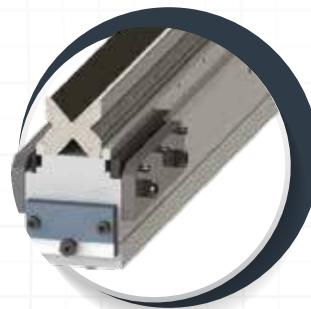

European Type
Bottom Tool (4V Die)



Quick
Release Clamping

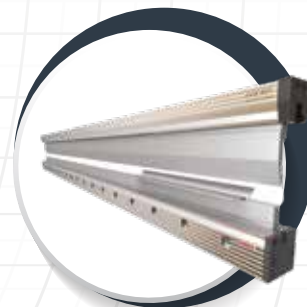

DURMA Hydraulic
Holder



DURMA Top
Tool Holder



DURMA Multi
V Bottom Tool

SAFE AND ACCURATE BENDS WITH TOP QUALITY EQUIPMENTS

■ Crowning System

Manual or CNC-controlled motorized crowning system simplifies bending, by adjusting each point of the bending parts to acquire straight bends. The need for shimming is eliminated.

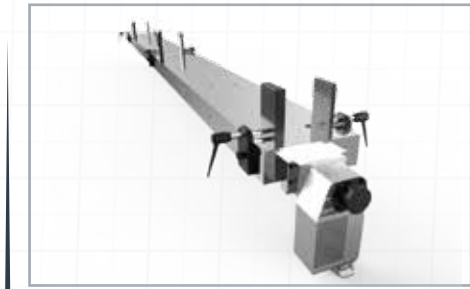

CNC Crowning System

■ Linear Guide Front Sheet Supports

Rugged support arms with tilting stops are mounted on a linear guide rail system. This allows 'finger-tip' lateral adjustment as required by the bend length of the part. They are also equipped with side gauges for the fast, easy, and accurate feeding of parts small or large.



Linear Guide Front Sheet Supports

■ CE Safety Systems

Our machines are designed in accordance with CE-Norms to ensure your safety with hydraulic, electric, appropriate height covers and laser light curtains. CE safety in tandem machines are also provided with light barriers.



CE Laser Safety System

■ Stable Top Beam Movement

By using long and planar guiding surfaces, all the disadvantages of point guiding are eliminated 100% free bending space: guiding system that eliminates bending between frame has been moved to the outside of the frame.



90 Degree Endless Bend

NOW BENDING IS MORE EASIER

■ SKY 22 (Optional)



- 21.5" TFT color touch screen with USB port and backup
- Automatic bending order
- Perfect control of electrical servo systems
- Archiving user bendings
- 2D/3D color graphics display and multi-simulation
- Windows 10 operating system
- D-Bend offline software
- Tandem applications
- Network interface
- X1-X2-R1-R2-Z1-Z2 and AP3-AP4 part support system
- DURMA laser angle measurement system compatible
- 2D / 3D part & tool import
- Robot integration compatible

■ DT 15 (Standard)



- Ergonomic panel design
- 15" color touchscreen
- Manual profiling on the touchscreen
- Diagnostic mode
- Easy programming mode
- Automatic bend sorting
- Multi-language option
- Tool programming and library
- D-Bend offline software
- Tandem compatible
- Internet service facility

■ DA-66T (Optional)



- 2D graphical touch screen programming mode
- 3D visualisation in simulation and production
- 17" high resolution colour TFT
- Full Windows application suite
- Delem modusys compatibility
- USB, peripheral interfacing
- User specific application support within the controllers multitasking environment
- Sensor bending & correction interface
- Profile - TL - software

■ DA-69S (Optional)



- 24" TFT screen, 1920 x3080 pixels, 32 bit colour,
- Real-time Linux embedded OS
- Full touch screen control
- Storage capacity 2 GB
- Network connectivity
- Delem modusys compatible
- Tandem operation
- 2D/3D real-scale product programming and visualisation
- Automatic bending calculation 2D/ 3D
- DXF part & tool import support

Production is *More Effective Now.*

■ System of DURMA Angle Measurement

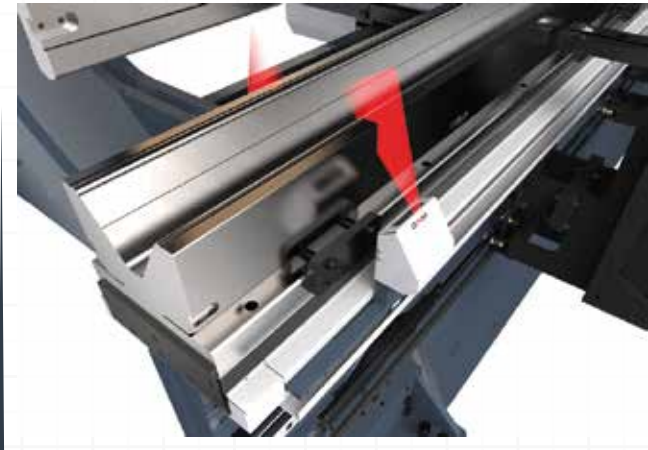

■ Automatic AP3 - AP4 Sheet Follower



■ Robotic System of Applications





SPECIAL PROJECTS



AD-S

AD-S SERIES TECHNICAL DETAILS

AD-S Series	Bending Force	Bending Length	Distance Between Columns	Stroke	Daylight	Throat Depth	Table Height	Table Width (Narrow / Wide)	Working Speed		Y Return Speed	Y Axis Precision	X Axis Working Speed
									Y Rapid Speed	Y Working Speed			
									mm/sec	mm/sec			
	Ton	mm	mm	mm	mm	mm	mm	mm	mm/sec	mm/sec	mm/sec	mm	mm/sec
		A	B	C	D	E	F	G					
AD-S 1260	60	1250	1050	160	400	350	900	104	200	10	110	0,01	500
AD-S 2060	60	2050	1700	265	530	450	900	104	200	10	110	0,01	500
AD-S 25100	100	2550	2200	265	530	450	900	104	180	10	120	0,01	500
AD-S 30100	100	3050	2600	265	530	450	900	104/180	180	10	120	0,01	500
AD-S 30135	135	3050	2600	265	530	450	900	104/180	160	10	120	0,01	500
AD-S 30175	175	3050	2600	265	530	450	900	104/240	160	10	100	0,01	500
AD-S 30220	220	3050	2600	265	530	450	900	104/240	140	10	140	0,01	500
AD-S 30320	320	3050	2600	365	630	450	900	154/300	160	10	140	0,01	500
AD-S 37175	175	3700	3100	265	530	450	900	104/240	140	10	100	0,01	500
AD-S 37220	220	3700	3100	265	530	450	900	104/240	160	10	120	0,01	500
AD-S 40175	175	4050	3600	265	530	450	900	104/240	160	10	140	0,01	500
AD-S 40220	220	4050	3600	265	530	450	900	104/240	160	10	140	0,01	500
AD-S 40320	320	4050	3600	365	630	450	900	154/300	160	10	140	0,01	500
AD-S 40400	400	4050	3400	365	630	510	1050	154/300	140	8	120	0,01	350
AD-S 60220	220	6050	5100	265	530	450	1050	154/300	140	10	120	0,01	350
AD-S 60400	400	6050	5100	365	630	510	1220	154/300	120	8	100	0,01	350

Production is *More Effective Now.*

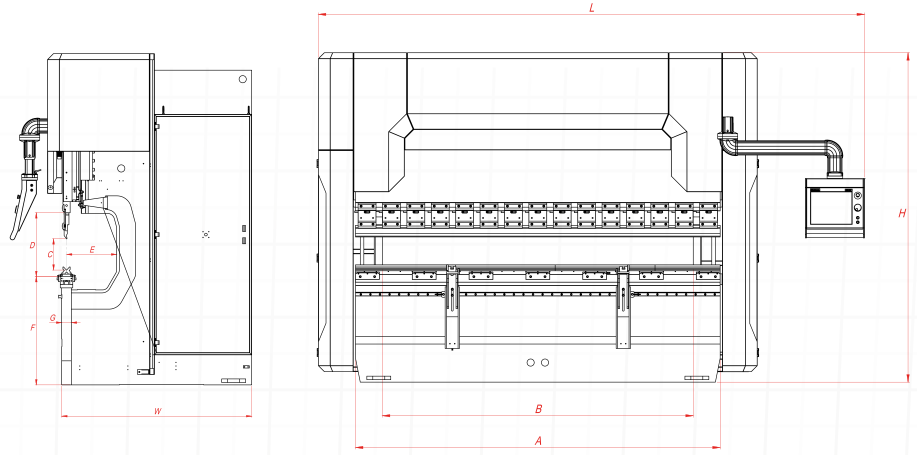

X Axis Precision	X Axis Distance			R Axis Working Speed	R Axis Working Distance	R Axis Precision	Z Axis Working Speed	Z Axis Working Distance	Motor Power	Oil Tank Capacity	Length	Width	Height	Weight Approx.
	650	750	1000											
mm	mm	mm	mm	mm/sec	mm	mm	mm/sec	mm	kW	lt	mm	mm	mm	kg
0,05	S	-	O	350	250	0,1	1000	490	7,5	100	2300	1550	2350	4700
0,05	S	-	O	350	250	0,1	1000	1100	7,5	100	3200	1550	2850	5600
0,05	S	-	O	350	250	0,1	1000	1580	11	100	3800	1670	2850	7800
0,05	S	-	O	350	250	0,1	1000	1990	11	100	4200	1670	2850	8500
0,05	S	-	O	350	250	0,1	1000	1990	15	150	4200	1680	2850	9580
0,05	S	-	O	350	250	0,1	1000	1990	18,5	250	4250	1700	2850	10900
0,05	S	-	O	350	250	0,1	1000	1990	22	250	4250	1770	3000	12600
0,05	S	-	O	350	250	0,1	1000	1990	37	250	4300	1820	3330	17100
0,05	S	-	O	350	250	0,1	1000	2375	18,5	250	4950	1700	3000	11750
0,05	S	-	O	350	250	0,1	1000	2375	22	250	4950	1770	3000	14440
0,05	S	-	O	350	250	0,1	1000	2910	18,5	250	5250	1700	2850	12780
0,05	S	-	O	350	250	0,1	1000	2910	22	250	5250	1770	3000	14750
0,05	S	-	O	350	250	0,1	1000	2910	37	250	5300	1910	3330	20000
0,05	-	S	O	300	250	0,1	1000	2670	37	500	5750	2110	3640	27760
0,05	-	S	O	300	250	0,1	1000	4400	22	250	7500	1770	3350	20800
0,05	-	S	O	300	250	0,1	1000	4400	37	500	7500	2110	3810	34600

S : Standard

O : Optional

AD-S

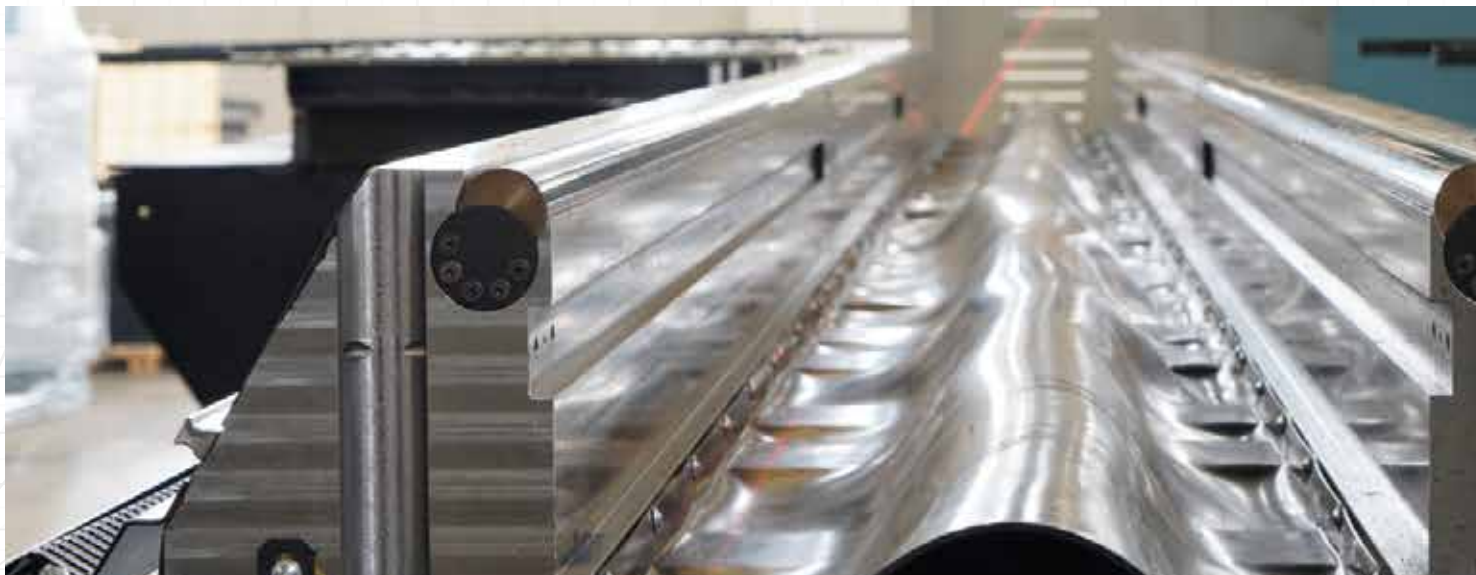

Production is *More Effective Now.*



STANDARD & OPTIONAL EQUIPMENT

Standard Equipment

Y1, Y2, X - 3 Axis Control Unit - DT 15
Manual F. AKAS FPBS Security system
Servo motor back gauge & linear guided & ballscrew system (X)
Manual Crowning system
European style tool clamping system
Sliding front arms
World standards special design hydraulic block and valves
World standard electric equipment

Optional Equipment

Control Unit - DA 66T - 69S - Sky 22
Motorized F. AKAS - 3P FPSC (Safety PLC)
F.AKAS LC-5 Security system
Manual F. AKAS FPSC Security system
CE F.AKAS BVLTLight barrier and safety cages (For Tandem Press Brake)
Delta X Axis 125 stroke
X Axis = 1000 mm - light barrier back protection
AP3-AP4 Automatic system of sheet follower - Motorized elevation adjustment
(There is a motorized elevation adjustment of 220 tons or more.)
Durma laser angle measurement
DBEND 3D bending simulation program
Quick release clamping system
Hydraulic and pneumatic tool clamping systems
Parking area
Central lubrication system manual / automatic
Oil cooler / Oil heater
Additional back gauge finger and sliding front support arms
Special packing for overseas shipments

Production is *More Effective Now.*

FAST ON SERVICE AND SPARE PARTS

DURMA provides the best level of service and spare parts with qualified personnel and spare parts in stock. Our experienced and professional service personnel are always ready at your service. Our professional training and application enriched courses will give you an advantage to use our machinery.







Product Groups

DURMA



Durmazlar Makina San. Tic. A.Ş. has right to change catalogue values and machine technical details without notice.

 Durma International
 durmainternational
 durmaint
 durmamachines
 Durmazlar



EN 2023/10.V.01



Durmazlar Makina San. ve Tic. A.Ş.
OSB 75. Yıl Bulvarı Nilüfer-Bursa /
Türkiye

P: +90 224 219 18 00

F: +90 224 242 75 80

info@durmazlar.com.tr

www.durmazlar.com.tr